

Consideration on a Low Power Solar Energy Renewable Source

Nistor Daniel Trip^{*}, Viorel Popescu^{**}, Jaroslav Dudrik^{***} and Andrei Maruşca^{****}

^{*}Department of Electronics,
University of Oradea, Faculty of Electrical Engineering
and Information Technology,
Universitatii St., no.1, 410087 Oradea, Romania,
E-Mail: dtrip@uoradea.ro

^{***}Technical University of Košice,
Faculty of Electrical Engineering and Informatics,
Letná 9, Košice, 042 00, Slovak Republik

^{**}Department of Applied Electronics,
University "Politehnica" of Timișoara, Faculty of Electronics
and Telecommunications,
Bd.V. Pârvan 2, 300223 Timișoara, Romania,

^{****}University of Oradea, Faculty of Electrical Engineering
and Information Technology, Specialization Electronics

Abstract – This paper presents the contribution of the authors regarding the implementation of a low power solar energy renewable source. To optimize the conversion efficiency of the solar irradiance into electrical energy an embedded system was designed. The embedded system can accomplish the maximum power point tracking by evaluation the output voltage and current of the photovoltaic panels and calculate a proper command for the DC-DC converter of the renewable source. The key device in this system is a midrange 8 bit microcontroller that consists of acquisition, command and control integrated hardware resources.

Keywords: maximum power point tracking, photovoltaic panel, embedded system, DC-DC converter

I. INTRODUCTION

Nowadays to produce green energy is a must. The most common green energy results from many kinds of renewable energies [1], such as: wind energy, geothermal energy, and not at last the solar energy. The main advantage of these energies is that they have no negative impact on the human beings and on the environments. Other important characteristics of these energies are their reduced cost and the fact that they are renewable. Solar energy can usually be converted in thermal energy to warm the water by means of the thermal solar panels. Solar energy can also be converted in electrical energy by means of the photovoltaic panels. Photovoltaic panels consist of a large matrix of photocells [1], very similar with photodiodes but with a larger surface of the P-N junction, that are connected in series to assure a high enough output voltage and then connected in parallel to assure an important output current. Taking into account these remarks one can observe that the photovoltaic panel acts as a nonlinear device able to generate a current to a DC load when the panel is exposed at the light from the sun. Many basic works and manufacturer mention for a panel a so called maximum power point for a given solar radiation. This characteristic is important due to the fact that the

efficiency of the photovoltaic panels is usually comprised between 10 and 15%, so it is small, and for this reason the other power losses are no longer accepted. Another important condition to avoid the poor use of photovoltaic panels is to use a DC-DC power converter between the panel and the load. The role of this circuit is to adapt the output electric parameters of the photovoltaic (PV) panel to the requirements of the load. For example, if one wishes to charge a battery directly from the PV panel observes that not all the power that can be supplied by the PV panel for a given solar radiation is used. The progresses in the field of power electronic devices manufacturing assure the accomplishment of DC-DC converters that present a high enough efficiency. The pulse width modulation (PWM) technique is involved to control these power converters [2]. Unfortunately, there is no specialized device able to assure the command of the DC-DC power converters following the maximum power point of a PV system. A good solution to this problem is to use a last generation microcontroller [3], [4], [5]. In this device one can implement different control algorithms for the optimization of the solar energy conversion. There are many families of microcontrollers that consist of A/D converters and PWM circuits used to process the variables of the system and to produce a proper command and control to assure maximum energy conversion efficiency. Also, using a microcontroller and its powerful characteristics the costs of the command circuit are very small. The use of a microcontroller gives to the designers a greater flexibility in the implementation of the command strategy. The main role of the embedded system is to test the maximum power that the PV panel is able to supply for a given radiation and tacking into account this result to elaborate a proper command for the power converter to assure the transfer of the whole available energy from the PV panel. Due to the powerful operation options of the microcontroller and its high processing power, the embedded system has also other important tasks such as: regulation and limit the output voltage of the DC-DC power converter, protection to the over load of the output circuit and could offer a user interface to display data.

II. PHOTOVOLTAIC PANELS

The PV panel consists of a complex array of solar cells. As it was mentioned above, a solar cell looks like a silicon photodiode but the surface of the P-N junction is higher to favor a better conversion of the light into electric current. Moreover, the solar cell consists of few particular specific elements [1], related more with the manufacturing technology and not with the operation principle. The equivalent electronic circuit for a solar cell is depicted in the Fig.1.

The component parts from Fig.1 are the following:

I_G – current generated by the solar radiation $h\nu$ that is in direct proportion; D – ideal equivalent internal diode that arises due to the P-N junction; U_D , I_D – voltage and the current of the diode D ; r_1 – equivalent resistance of the structure at low values of the voltage U_D ; r_2 – metal-semiconductor equivalent series resistance; R_S – load resistance and U_S , I_S – load voltage and current. If the R_S and the level of solar radiation are high enough then the resistance r_2 and r_1 respectively can be neglected. Taking into account this last approximation and the relation (1) that represents the current through the ideal diode D :

$$I_D = I_O \left(e^{\frac{U_D}{\eta U_T}} - 1 \right) \quad (1)$$

where U_T is about 26mV and represent the thermal voltage at 27°C and η depends on the type of the semiconductor and the voltage over the P-N junction, one can derive the load current of the solar cell

$$I_S = I_G - I_O \left(e^{\frac{U_D}{\eta U_T}} - 1 \right) \quad (2)$$

From relations (1) and (2) one can obtain the following relation that gives the open circuit voltage U_{SO} of the solar cell without the load:

$$U_{SO} = U_D = \eta U_T \ln \left(1 + \frac{I_G}{I_O} \right) \quad (3)$$

When the load is short circuited the output current of the solar cell I_{SS} is the very same with I_G .

An important parameter of the solar cell is the maximum power it can supply to the load. The output power that is generated by the solar cell when it is exposed to a solar radiation is given in the next relation:

$$P = U_S \cdot I_S = U_S \left[I_G - I_O \left(e^{\frac{u_s}{\eta U_T}} - 1 \right) \right] \quad (4)$$

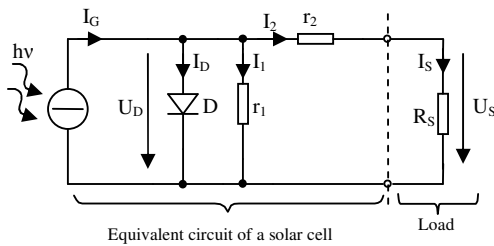

Fig.1. Model of a solar cell

One can find the maximum value of the output power if the next relation is accomplished:

$$\frac{dP}{du_s} \Big|_{U_S=U_M} = 0 \quad (5)$$

where U_M is the output voltage for which the maximum output power P_M is obtained. Equation (5) yield further:

$$\frac{I_G}{I_O} + 1 = e^{\frac{U_M}{\eta U_T}} \left(1 + \frac{U_M}{\eta U_T} \right) \quad (6)$$

Equation (6) can be solved numerically to obtain the value of the output voltage U_M that cause the maximum power transfer to the load.

The representation of the output power for a solar cell, with dashed line in Fig.2, exposed at a constant solar radiation. In Fig.2 one can see also the output voltage versus output current for a solar cell with a resistive load.

An important remark can be done related to the u-p characteristic of a solar cell from Fig.2. On the right side and the left side of the maximum power point P_M the ratio $\frac{\partial p}{\partial u} < 0$ and $\frac{\partial p}{\partial u} > 0$ respectively. The properties shown in Fig.2 are given for a constant solar radiation and temperature.

As we mentioned above, a PV panel consist of a complex array of solar cells connected in series and in parallel. For a solar cell, the output voltage is smaller than 0.7V and for this reason, to obtain a higher voltage at the output of a PV panel that can be used effectively as supply source, it is necessary to connect more solar cells in series. The output current of a solar cell is about 20mA [1]. To obtain in a PV panel a higher current after the conversion of the solar radiation in electricity, more solar cells are connected in parallel.

III. MAXIMUM POWER POINT TRACKING SYSTEM

There are two main ways to improve the conversion efficiency of a PV panel. In the first case, to assure the highest energy conversion the PV panel must look out on the sun all the time during the day.

For this method it is necessary a mechanical guidance system able to change the position of the panel towards the sun such that the solar rays to arrive upright at the surface of the panel. The second possibility that offer an optimized energy conversion of the PV panel is based on the condition mentioned in (5) and it is described further.

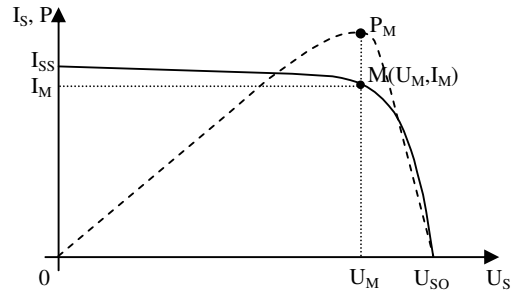

Fig.2. Maximum power point for a silicon solar cell

In the Fig.3 one can see two possibilities to use the PV panels for different types of loads and in Fig.4 it is shown the u-i characteristic and u-p characteristic of the PV panel with solid line and dashed line respectively together with the load properties.

The load characteristics 1 and 2 depicted in Fig.4 for the circuit shown in Fig.3.a denote that the output power of the photovoltaic panel P_V depends on the value of the load resistance. One can easily observe the decrease of the output power P_2 and P_1 when the values of load resistance become smaller R_2 respectively R_1 . Another situation is shown in Fig.3.b when a rechargeable battery is connected directly to the PV panel. In this case the battery force the panel's output voltage to the value of its output voltage U_{AC} as it is depicted in characteristic 3 in Fig.4. In all above examples the temperature of the environment where the PV panel operates is considered constant. One can see that in each example the output power of the panel is lower than the maximum power P_M that can be supplied by the PV panel exposed at a certain constant solar radiation. As a consequence of these examples it is recommended to avoid or at least limit the direct connection of any kind of loads to the PV panels when a maximum energy conversion is required. Nowadays, DC-DC power converters with PWM control are used to make the connection between the PV panels and DC consumers as one can see in Fig.5.

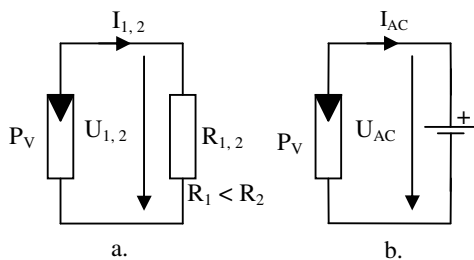

Fig.3. PV panel as a power supply for different loads

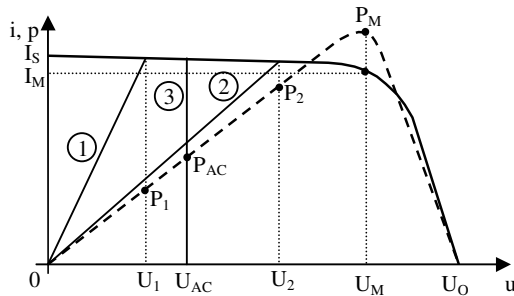

Fig.4. Level of power supplied by a PV for different loads

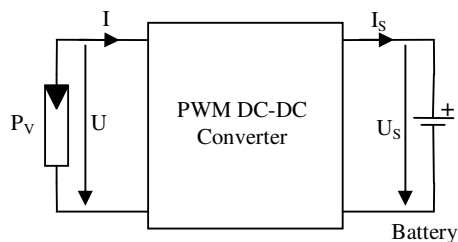

Fig.5. Solar energy conversion circuit

The DC-DC converters have input impedance that can be controlled by the duty cycle of the command signals [2]. In this case, the converter is controlled to take over the maximum power the PV panel can generate it to the load. This operation is accomplished by the help of the “perturb and observe” algorithm [4], [5], whose logic diagram is shown in Fig.6.

The algorithm introduces periodically a small perturbation in the command of the DC-DC converter to change the value of the take over energy. The perturbation is in fact a small change in the duty cycle of the converter. After this perturbation, the average input current of the converter is changed and this modifies also with a small constant value the output power generated by the PV panel. Then, the new value of the output power of the PV panel is compared with the value obtained before the moment the perturbation was introduced. If the output power increase than the direction of the perturbation is kept and another perturbation with the same value is imposed. This process continues till the value of the output power of the PV panel become negative in comparison with the previous estimation. When this thing happens, it means that the maximum power point was overpass and it is necessary to inverse the direction of the imposed perturbation. Due to the fact that the perturbation introduces a constant variation of the output power, the perturbation may change its direction around the maximum power point. In Fig.6 is shown how to obtain the requested duty cycle for the converter's command to attain the maximum power point of the PV panel. The input voltage and current of the converter is measured and by their help is calculated the actual output power of the PV panel. The direction of the perturbation in duty cycle “dalpha” is chosen after the comparison of the last value of the output power and the previous one. Then the new value of the duty cycle “alpha” is obtained.

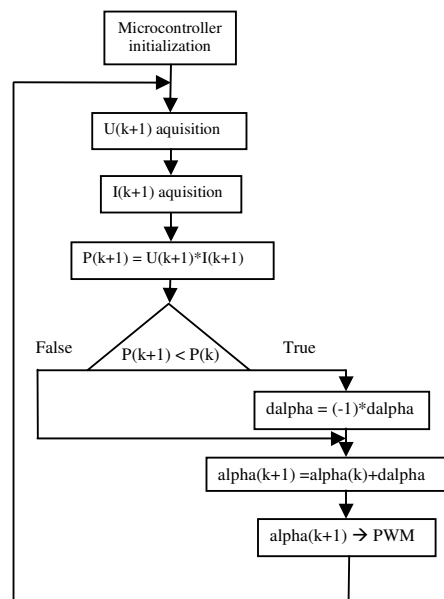

Fig.6. Logic diagram of the maximum power point tracking “perturb and observe” algorithm

Till now, there are no specialized integrated circuits that operate according to the “perturb and observe” algorithm. The algorithm could be easily developed on embedded systems instead. The proposed system is depicted in Fig.7. The system consists of DC-DC converter buck topology and an 8 bit microcontroller. The circuit also consists of three classic sensors that adapt the value of the input voltage, input current and output voltage of the converter to the dedicated inputs of the microcontroller. The microcontroller comes with 10 bits resolution and 14 channels A/D converter and 10 bit resolution PWM module.

To obtain a proper charge of the battery, the value of the inductance L was designed so that the DC-DC buck converter to operate in discontinuous conduction mode. In this way, the battery is charged by a pulsating current. Tacking into account the turn-off time interval of the main switch of the converter, the value of the duty cycle was limited to the 0.8

IV. EXPERIMENTAL RESULTS

For simulation and experimental results was used a PV panel with the following characteristics: peak power 5W, maximum power point voltage 18V, maximum power point current 0.29A, open circuit voltage 21.96V and short circuit current 0.326A.

The following experiments were carried out at a switching frequency of 8KHz and a 12V/4A rechargeable battery.

Fig.8 and Fig.9 show the voltage u_D and current i_L for a solar irradiance of $0.3KW/m^2$. It is also presented the command voltage for the transistor T_1 at the output PWM pin RC2 of the microcontroller

V. CONCLUSIONS

In this paper is justified the necessity to use a system able to track the maximum power point of a PV panel especially when the manufacture peak power of the panel is small. In the work are also presented a model for a solar cell, simulation results for solar cell model, algorithm “perturb and observe”, and implementation of a system able to track the maximum power point of a PV panel using a microcontroller.

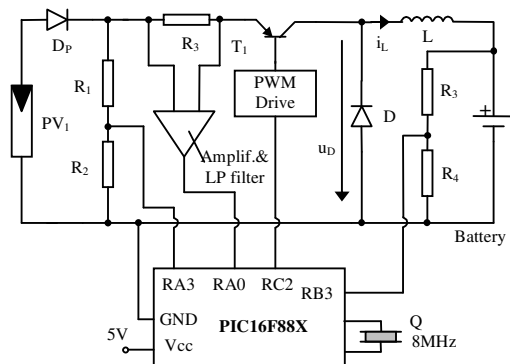

Fig.7. Conversion system

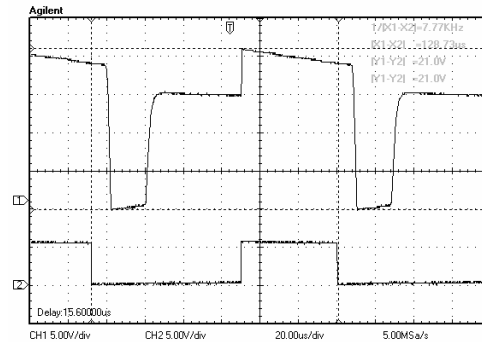

Fig.8. Below - command voltage and above - the u_D voltage at $0.3KW/m^2$ irradiance

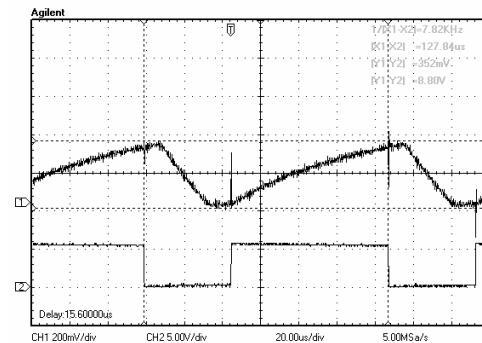

Fig.9. Below - command voltage and above - the wave shape of the i_L current at $0.3KW/m^2$ irradiance
The experimental results validate the good operation and utility of the proposed system. The proposed system is also useful for learning process in laboratory activity for the courses: power and industrial electronics and embedded systems.

ACKNOWLEDGEMENT

This scientific work is a part of the research project A/814/2007 at commission 2, granted by the National University Research Council from Romania.

REFERENCES

- [1] T. Maghiar, K. Bondor, “New sources of energy” (in romanian), Editura Universității din Oradea, Oradea, 2001.
- [2] V. Popescu, “Power Electronics” (in romanian), Editura de Vest, Timișoara, 1998.
- [3] W. Xiao, M.G.J. Lind, W.G. Dunford, A. Capel, “Real-Time Identification of Optimal Operating Points in Photovoltaic Power Systems”, IEEE Transactions on Industrial Electronics, Vol. 53, Issue 4, June 2006, pp. 1017 – 1026.
- [4] J.H.R. Enslin, M.S. Wolf, D.B. Snyman, W. Swiegers, “Integrated photovoltaic maximum power point tracking converter”, IEEE Transactions on Industrial Electronics, Volume 44, Issue 6, Dec. 1997, pp. 769 – 773.
- [5] N. Femia, G. Petrone, G. Spagnuolo, M. Vitelli, “Optimization of perturb and observe maximum power point tracking method”, IEEE Transactions on Power Electronics, Volume 20, Issue 4, July 2005, pp. 963 – 973.